

FIRE RESISTANCE CLASSIFICATION REPORT No. 21778C

OWNER OF THE CLASSIFICATION REPORT

JORIS IDE nv
Hille 174
8750 ZWEVEZELE
Belgium

INTRODUCTION

This classification report defines the classification assigned to a non-loadbearing partition wall consisting of vertically placed sandwich panels – external fire exposure, type: JI SF/FC/VB Wall 1000, thickness: 150 mm, in accordance with the procedures given in EN 13501-2:2016: Fire classification of products and building elements – Part 2: Classification using data from fire resistance tests, excluding ventilation services.

This classification report consists of 15 pages and 2 annexes and may only be used or reproduced in its entirety.

1 Details of classified product

1.1 General

The element – type: JI SF/FC/VB Wall 1000, thickness: 150 mm, is defined as a non-loadbearing partition wall consisting of vertically placed sandwich panels, with fire resistance characteristics – external fire exposure.

1.2 Description

The element, JI SF/FC/VB Wall 1000, thickness: 150 mm, is fully described below, in support of this classification. The drawings of the test element as it was tested, are enclosed in the annexes 1 till 2 of this classification report.

1.2.1 Composition of the test specimen as tested

The test specimen is an asymmetrical non-loadbearing wall consisting of vertically placed sandwich panels. The sandwich panels are fixed to the concrete furnace frame by means of L-profiles.

Outer dimensions of the test specimen:

- height: 3000 mm;
- width: 3000 mm;
- thickness: 150 mm.

1.2.2 Supporting structure

1. L-profile	
Material	Polyester coated steel
Thickness	0.55 mm
Section dimensions	Exposed side: 80 mm x 80 mm Unexposed side: 80 mm x 80 mm
Fixing to the concrete furnace frame	With wedge anchor (brand and type: Hilti DBZ 6/4.5, material: galvanized steel, diameter: 6.0 mm, length: 45 mm), c/c: 300 mm.

1.2.3 Sandwich panels

2. Sandwich panel	
Manufacturer	Joris Ide
Reference	JI Wall 1000SF (liner profile)
Thickness	148 mm
Dimensions	1000 mm (w) x 2940 mm (h)
Surface mass	13.90 kg/m ²
Joint system	See annex 2
Joint overlap	Unexposed side: 16 mm Exposed side: 48 mm
Panel orientation	vertically
Composed of	Exposed panel skin Insulation core Unexposed panel skin
Fixing to the L-profiles	With self-drilling screw with bonded washer (brand and type: Joris Ide Fastovis 6 + VG16, material: galvanised steel, diameter: 6.0 mm, length: 30 mm), c/c: 300 mm.
3. Unexposed panel skin	
Reference	LINEAR
Profile depth	1.3 mm
Material	Polyester coated steel
Sheet thickness	0.37 mm
Coating thickness	15 µm
Fixing to the core	Auto-adhesive insulation core
4. Insulation core	
Manufacturer	JORIS IDE
Reference	JI51G
Material	Polyisocyanurate foam
Thickness (d _c)	146 mm
Density	38.14 kg/m ³

5. Exposed panel skin	
Reference	LINEAR
Profile depth	1.3 mm
Material	Polyester coated steel
Sheet Thickness	0.55 mm
Coating thickness	25 µm
Fixing to the core	Auto-adhesive insulation core

1.2.4 Free edge cap

6. Free edge cap	
Profile type	L-profile
Number	2
Material	Galvanised steel
Thickness	1.00 mm
Dimensions	82 mm x 82 mm
Fixing	<p>With self-drilling screw with bonded washer on (brand and type: Joris Ide Fastovis 12 DF Zn + VG16, material: galvanised steel, diameter: 5.5 mm, length: 235 mm), c/c: 600 mm on both exposed and unexposed side.</p> <p>With self-drilling screw with bonded washer on (brand and type: Joris Ide Fastovis, material: galvanised steel, diameter: 6.0 mm, length: 100 mm), c/c: 400 mm on both unexposed and exposed side.</p>
7. Insulation	
Manufacturer	UNIFRAX
Reference	FIBERFRAX Durablanket Z
Material	Zirconia stabilised ceramic fibre
Thickness	25 mm
Density	96 kg/m ³ (NV)
Position	At the vertical free edge under the free edge cap.

1.2.5 Insulation

8. Insulation	
Manufacturer	Rockwool
Reference	Rockflex 214 MW-EN 13162-T2-MU1
Material	Stone wool
Thickness	80 mm/ compressed 25 mm
Density	37.26 kg/m ³
Position	Pressed tightly in-between the concrete furnace frame and the sandwich panels at the side edge and at the vertical fixed edge; and is then covered by the L-profiles. At the bottom horizontal edge, between the sandwich panels and the concrete furnace frame.

2 Test reports/EXAP reports and test results in support of the classification

2.1 Test reports/EXAP reports

Name of the laboratory	Report ref. no.	Name of the owner	Date of the test	Method
WFRGENT nv	21778A	JORIS IDE nv	27/01/2022	EN 1364-1:2015
WFRGENT nv	21778B	JORIS IDE nv	-	EN 15254-5:2018

Exposure conditions during the fire resistance test:

Temperature/time curve: external fire exposure curve T (°C), in accordance with EN 1363-2:1999.

Direction of exposure: The test specimen is an asymmetrical construction. The external panel skin with the large tong and groove system is exposed to the fire.

No extra load supplementary to the own weight of the non-loadbearing wall was applied during the test.

One vertical edge is free, the other edges are fixed.

2.2 Test results

Parameters	Results
Thermal insulation – I-ef	
$\Delta T_m = 140^\circ\text{C}$	93 minutes, no failure ⁽¹⁾
$\Delta T_M = 180^\circ\text{C}$	43 minutes
Integrity – E-ef	
Spontaneous and sustained flaming	93 minutes
Failure with gap gauge \varnothing 6 mm	93 minutes, no failure ⁽¹⁾
Failure with gap gauge \varnothing 25 mm	93 minutes, no failure ⁽¹⁾
Ignition of cotton pad	93 minutes, no failure ⁽²⁾
Radiation – W-ef	
Radiation intensity = 15 kW/m ²	93 minutes, no failure ⁽¹⁾

ef external fire exposure

⁽¹⁾ The test was discontinued after 93 minutes at the test sponsor's request.

⁽²⁾ No failure until the moment of failure of the thermal insulation (I).

3 Classification and field of application

3.1 Reference of classification

This classification has been carried out in accordance with clause 7 of EN 13501-2:2016.

3.2 Classification

The element, type: JI SF/FC/VB Wall 1000, thickness: 150 mm, is classified according to the following combinations of performance parameters and classes as appropriate. No other classifications are permitted.

The classifications are valid for the direction as stated in clause 2.1: The external panel skin with the large tong and groove system is exposed to the fire.

EI 30-ef span 7.5m, **EI 20-ef**, span 7.5m, **EI 15-ef**, span 7.5m

EW 90-ef span 4.0m, **EW 60-ef** span 7.5m, **EW 30-ef** span 7.5m,
EW 20 span 7.5m

E 90-ef span 4.0m, **E 60** span 7.5m, **E 30** span 7.5m, **E 20** span 7.5m

ef: external fire exposure curve

Span x m: the span length = height of the vertically placed sandwich panels is limited to x m for that particular classification

3.3 Field of direct application

This classification is valid for the following end use applications according to EN 1364-1:2015.

The results of the fire test are directly applicable to similar constructions where one or more of the changes listed below are made and the construction continues to comply with the appropriate design code for its stiffness and stability:

- a) unlimited increase in width of the wall;
- b) unlimited decrease in length of the wall of 3 m;
- c) increase in height of the wall up to 4 m, if the expansion allowances are increased pro-rata;
- d) increase in the thickness of the wall (≥ 150 mm);
- e) increase in the thickness of component materials;
- f) decrease in linear dimensions of panels, but not the thickness:
 - width (≤ 1000 mm);
 - height (≤ 2950 mm).
- g) decrease in distance of fixing centers:
 - of the L profiles to the edges of the surrounding building structure (≤ 300 mm);
 - of the screws fixing the panels to the L-profiles (≤ 300 mm);
- h) increase in the number of vertical joints;
- i) only vertical joints (of the type tested) are permitted;
- j) the use of surface fittings and fixtures is not permitted;
- k) The sandwich panel may be installed in rigid supporting construction which has the same or greater classified fire resistance than used in the test:
 - density (≥ 2000 kg/m³).

3.4 Field of extended application

The situation with combined variations is always very complex and shall be considered case by case. To be able to combine variations there shall be an overrun of at least 20 % subject to a minimum 10 min compared to the classification.

3.4.1 Metal facing: chemical composition of coating

Unexposed side:

- A change in emissivity of - 10 % for a new coating compared to the tested one is allowed for following classification and lower:
 - EI 30, EW 60 and E 60;
- Coatings with higher emissivity values compared to the tested one are allowed;
- If modifications in the coatings on the unexposed side are made compared to the tested one, the reaction to fire classification of the product shall be the same or better than the tested one. Test results are though valid for all colours of the same type of coating.

Exposed side:

- The test results are valid for all coatings.

Limitation: When a change in coating is made, the manufacturer of the coated sheet shall provide emissivity properties for the products.

3.4.2 Metal facing: change from coated to non-coated metal

Unexposed side:

- A change from a coated to a non-coated sheet is not allowed.

Exposed side:

- A change from a coated to a non-coated sheet is allowed.

3.4.3 Metal facing: sheet thickness

Allowed up to ± 0.2 mm of tested thickness.

3.4.4 Metal facing: change from one metal to another

The test results are valid for all grades of steel.

3.4.5 Metal facing: change in sheet geometry

Panels with different metal thicknesses on both sides are regarded as symmetrical if the difference in thickness is max. 0.2 mm.

3.4.6 Metal facing: changes in profile geometry of facing

Any change in the range 0 mm to 5 mm profiling is allowed if the declared tensile strength value is equal or higher than for the tested panel. The panels are regarded as symmetrical.

3.4.7 Changes in core material: type

Changes from one core material to another are not allowed.

It is not possible to extend the results from one core material producer to another core material producer.

3.4.8 Change in core material composition: polyisocyanurate (PIR)

The test results are only valid for the same chemical system and blowing agent.

The test results are valid for ± 10 % of tested density.

3.4.9 Span length: decrease/increase

A decrease in span length is allowed.

An increase in span length of up to 7.5 m is allowed for following classification and lower:

- EI 30, EW 60 and E 60.

Calculation of Δf :

Time (min)	Δf (mm)
10	-0.0051
20	-0.0057
30	-0.0034
40	0.0161
50	0.0285
60	0.0234
70	0.0125
80	0.0066
90	0.0037

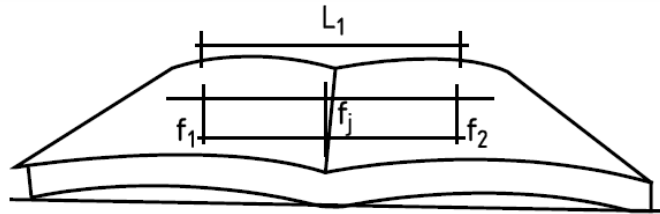

$$\Delta f = (f_j - 0,5 \times (f_1 + f_2)) / L_1$$

Calculation of Δc :

Time (min)	Δc (mm)
18	0.0435
25	0.0435

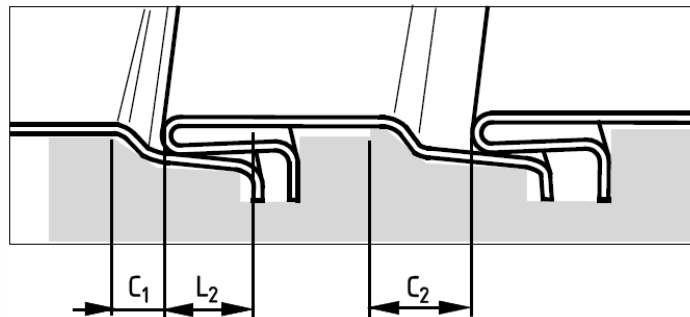

$$\Delta c = (c_2 - c_1) / L_2$$

To determine the amount of fasteners (n) required to support the extended weight up to 7.5 m the calculation below is used.

Tensile force:

Tensile force:

$$F_{t,Ed} = \frac{Lbq}{2} = \frac{7.5m \times 1.00m \times 0.3kPa}{2} = 1.125kN$$

Shear force:

$$F_1 = \frac{Lbq}{2} = \frac{7.5\text{m} \times 1.00\text{m} \times 0.3\text{kPa}}{2} = 1.125\text{kN}$$

$$F_2 = Lb \left(q + \frac{gL}{8b} \right) = 7.5\text{m} \times 1.00\text{m} \times \left(0.3\text{kPa} + \frac{0.1364\text{kPa} \times 7.5\text{m}}{8 \times 1.00\text{m}} \right) = 3.209\text{kN}$$

$$F_{v,Ed} = (F_1^2 + F_2^2)^{1/2} = \sqrt{1.125\text{kN}^2 + 3.209\text{kN}^2} = 4.011\text{kN}$$

with:

L = the panel span length (m)

b = the panel width (m)

q = the airpressure (0.3 kPa if nothing is specified) (kPa)

g = the own weight (kPa)

F_{t,Ed} and F_{v,Ed} = the calculated forces acting on the fasteners (kN)

Calculation for the amount of fasteners (n):

$$\frac{F_{t,Ed}}{F_{t,Rd}} + \frac{F_{v,Ed}}{F_{v,Rd}} \leq n k_{y,\theta}$$

$$\frac{1.125\text{kN}}{F_{t,Rd}} + \frac{3.209\text{kN}}{F_{v,Rd}} \leq n k_{y,\theta}$$

with:

F_{t,Rd} and F_{v,Rd} = the design tensile load on the used fastener in practice at normal temperature (kN)

k_{y,θ} = the decrease on the yield strength of the used steel according to EN 1993-1-2 (k_{y,θ} = 1 for steel temperature up to 400 °C, below 1 for steel temperature above 400 °C)

n = the number of fasteners

Limitation: It has to be noted that extension in span length is only allowed with tested panel orientation.

3.4.10 Variations in orientation

The test results are only valid for the tested orientation.

3.4.11 Panel width: decrease/increase

A decrease in panel width is allowed.

An increase in panel width is allowed up to 20 % of the tested width.

3.4.12 Panel thickness: decrease/increase

A decrease in panel thickness is not allowed.

An increase in panel thickness is allowed.

3.4.13 Joint construction: type

Even small changes in the joint construction can easily affect the integrity of the wall and shall not be allowed with the following exception:

- an increase in the overlap in the metal facing at the joint is allowed if other dimensions remain unchanged.

3.4.14 Joint construction: sealants

A sealant can be added in the metal joint on the exposed side.

3.4.15 Fixing to the surrounding building structure decrease/increase

Minor changes in the boundary conditions and fixing system (for example an increased amount of fasteners, increased diameter of fasteners; but material cannot be changed) are allowed provided that it can be shown that the bearing capacity is not reduced and the risk of collapse is not increased according to calculations given in **3.4.9**.

3.4.16 Length of assembly: vertical installation

The length of the wall can be freely increased.

3.4.17 Chance of the support Structure

In practice, the panel assembly can be fixed to different types of support structures. The test results shall be valid if the following requirements on the support structure are fulfilled:

- the support structure has at least the same fire resistance classification time for loadbearing capacity (R) as the panel assembly has for insulation and/or integrity;
- the fixing system has the same loadbearing capacity (R) in the support structure as in the frame used in the reference test;
- The fixation area can also be protected with thermal insulation. If such thermal insulation is used in the test, thermal insulation with at least same fire performance shall also be used in end use conditions.

4 Limitations

This classification report does not represent type approval nor certification of the product.

SIGNED

APPROVED

This document is the original version of the classification report and is written in English.

In case of doubt, the most recent version prevails, originally issued in English.

This report may be used only literally and completely for publications. - For publications of certain texts, in which this report is mentioned, our permission must be obtained in advance.

The authenticity of the electronic signatures is assured by Belgium Root CA.

Front view (unexposed side) - dimensions

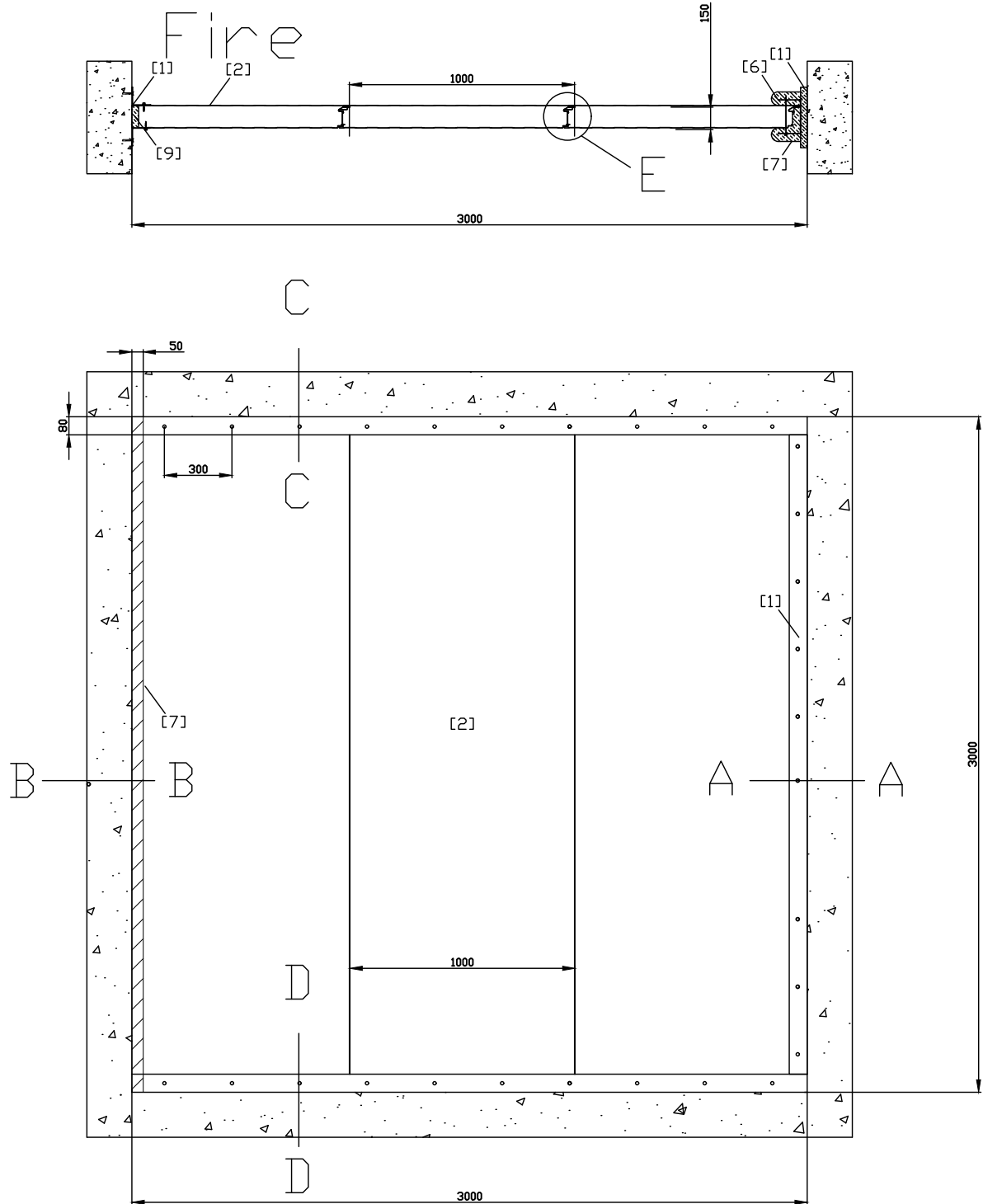

Section details A-A, B-B, C-C, D-D and detail E - dimensions

A:A FIXED SIDE
 2*L (80*80*0,5mm)

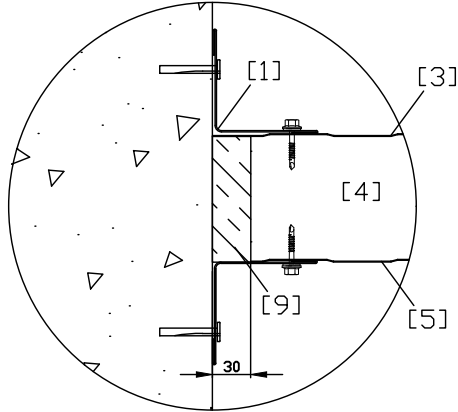

C:C TOP
 2*L (80*80*0,5mm)

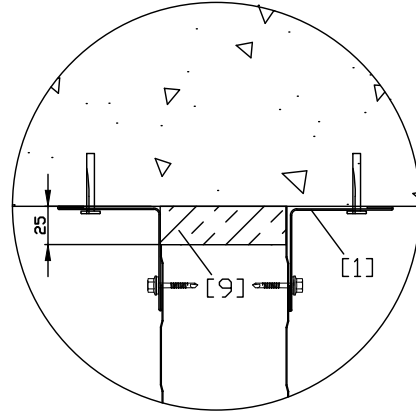

D:D BOTTOM
 2*L (80x80x0,5mm)

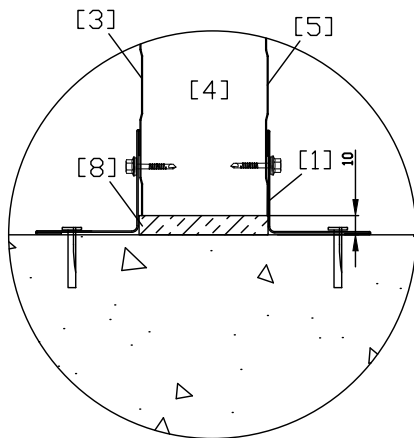

B:B FREE SIDE
 2xL (80*80*1mm)

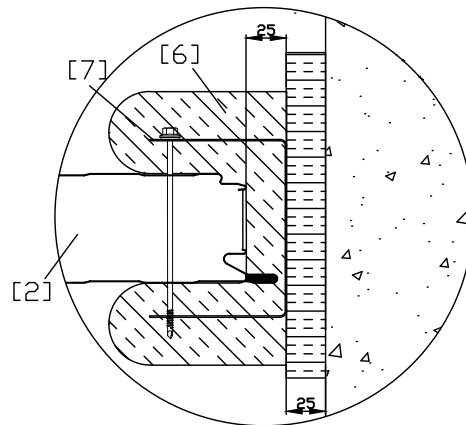

DETAIL E

